

# 9000MD MAG-COUPLED GEAR PUMP FROM ZENITH PUMPS

AFFORDS SAFE OPERATION WHILE PRECISELY METERING DANGEROUS FLUIDS.

Since 1926, Zenith established a worldwide standard of excellence for innovative gear metering pump designs that are consistently used in the most critical fluid metering applications. Zenith's 9000MD again shows our commitment to industry that Zenith can provide quality products and services needed in order to meet today's rigorous demands.

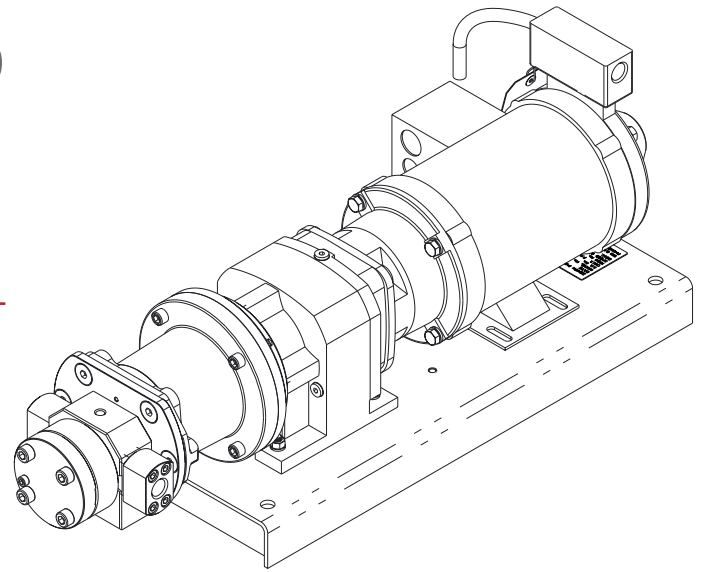

The 9000MD offers a static seal alternative to traditional mechanical and compression type dynamic seals. A permanent magnetic coupling transmits torque by magnetic forces between the internal and external rotors, through a statically sealed barrier. The barrier is constructed from stainless steel, nickel alloy or other corrosion resistant material and is not contacted by either the inner or outer rotor.

The pump head is coupled to NEMA 56C/140TC framed motors, either AC or DC, which allows the motor to be removed from the pump housing without difficulty. Pump speeds are limited based on the pump of choice. The system can be close coupled without the need of a gear reducer. The 9000MD eliminates shaft leakage of hazardous fluids, increases plant safety, and reduces VOC emissions. The magnetic coupling also reduces downtime due to excessive mechanical seal failures and eliminates the need for buffer fluids.

Zenith's magnetically coupled pump designs include the B-, C-, and H-9000 models. The B-9000 pumps are made of through hardened 400 series SS while the C-9000 is constructed from hardened 316 SS/compatible materials and H-9000 is constructed from hardened tool steel. This new seal design can be retrofitted to any existing 9000 series pump ranging from 0.05 to 90 cc/rev. Zenith's C-9000 is primarily used for non-lubricating, corrosive and/or thin fluids, where 316 SS compatible materials of construction are usually desired. The B-9000 is considered a chemical duty metering pump suitable for a variety of chemical metering applications. The H-9000 is primarily used for lubricating fluids and fine abrasives.

## DESIGNED TO DELIVER

The Zenith 9000MD offers the following features and benefits.

- › **Eliminates shaft seal leakage** – No fugitive emission whatsoever, no leak to capture, nothing to clean-up
- › **Eliminates shaft seal wear** – No daily adjustment of packing, no shut-down for seal replacement.
- › **Eliminates the need for double seals and buffer liquids** – No contact between liquid and external atmosphere, no precipitation or freezing at the seal.
- › **Corrosion resistant** – Stationary can and internal magnet encased in 316 stainless steel, titanium stabilized.

## CRITICAL FLUID METERING APPLICATIONS INCLUDE

- › General Chemical
- › Corrosive / Poor Lubricity
- › Abrasive / High Temperature
- › Release agents
- › Catalysts
- › Hazardous



Magnetic Coupling Pump Options/ Capabilities:	B- / H- 9000 Series - Industrial Duty Constructed of through hardened 400 Stainless / Tool Steel	C-9000 Corrosive/Non-Lubricating Constructed of hardened 316 SS and compatible materials
Capacities:	0.05, 0.3, 0.6, 1.2, 2.4, 4.5, 9.0, 15, 30, 45, 90	0.3, 0.6, 1.2, 2.4, 4.5, 9.0
Recommended Speeds:	Up to 500 RPM	Up to 1000 RPM
Flow Range:	Up to 27,000 cc/min or up to 7.1 GPM	Up to 9000 cc/min or up to 2.4 GPM
Inlet Pressure:	300 Psi (20 Bar) Maximum	300 Psi (20 Bar) Maximum Outlet
Pressure:	1000 Psi (70 Bar) Maximum	1000 Psi (70 Bar) Maximum
Differential Pressure:	20 to 1000 Psi (viscosity dependent)	20 to 1000 Psi (viscosity dependent)
Temperature:	0° F (-18° C ) Minimum 400° F (205° C) Maximum	-15° F (-25° C ) Minimum 350° F (175° C) Maximum
Seal Type:	Rare Earth - Samarium Cobalt Magnets	Rare Earth - Samarium Cobalt Magnets
Port Connections:	Metric thread or SAE 61 Standard	Metric thread or SAE 61 Standard
Optional Port Adapters:	M12 X 1/4" NPT 0.05 - 2.4 cc/rev 1/2" SAE X 1/2" NPT 4.5 - 9.0 cc/rev	M12 X 1/4" NPT 0.3 - 2.4 cc/rev 1/2" SAE X 1/2" NPT .45 - 9.0 cc/rev

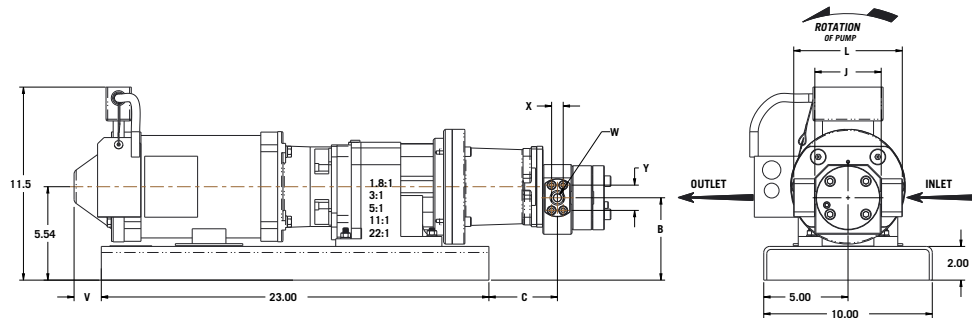

System Configuration	Magnetic Coupling	B	C	J	L	Motor Overhang, V	W	X	Y	Motor NEMA
0.5 - 2.4 cc/rev 1/2 HP AC, with Reducer	23 in-lb	4.89	2.95	2.76	4.4	1.6	¼" NPTF	N/A	N/A	56-C
0.5 - 2.4 cc/rev 1 HP AC, with Reducer	55 IN-LB	4.89	2.95	2.76	4.4	1.6	¼" NPTF	N/A	N/A	56-C
4.5 - 9.0 cc/rev 1/2 HP AC, with Reducer	110 IN-LB	5.08	4.06	3.94	6.5	1.6	½" NPTF	0.69	1.5	56-C
4.5 - 9.0 cc/rev 1 HP AC, with Reducer	110 IN-LB	5.08	4.06	3.94	6.5	1.6	½" NPTF	0.69	1.5	56-C
4.5 - 9.0 cc/rev 2 HP AC, with Reducer	110 IN-LB	5.08	4.06	3.94	6.5	1.6	½" NPTF	0.69	1.5	140-TC
15 -30 cc/rev 1- 2 HP AC, with Reducer	440 IN-LB	34" BASEPLATE LENGTH. CONTACT FACTORY FOR DIMENSIONS AND PORTING OPTIONS								
45 -90 cc/rev 1- 2 HP AC, with Reducer	700 IN-LB	34" BASEPLATE LENGTH. CONTACT FACTORY FOR DIMENSIONS AND PORTING OPTIONS								



ZENITH®

CIRCOR | ZENITH  
 1710 Airport Road  
 Monroe, NC 28110  
 Phone: 877-853-7867  
 Contact: <http://www.circorpt.com/contact>  
[www.zenithpumps.com](http://www.zenithpumps.com)